

部品番号	部品名	注記	個数
1	SHASSIS	SPCC-SD t1.6 焼き付け塗装	1
2	基板A		1
3	基板		1
4	基板		1
5	基板		4
6	基板		1
7	電源基板		1
8	コイル大		1
9	コイル中		1
10	コイル中小		1
11	コイル小		2
12	コイルブラケット	SPCC-SD t2.0 ユニクロメッキ	2
13	COVER	SPCC-SD t1.6 焼き付け塗装	1
14	Front Panel	A5052-H34 t2.0 HL 黒アルマイト	1
15	基板C-		1

UNLESS OTHERWISE SPECIFIED:
 DIMENSIONS ARE IN MILLIMETERS
 SURFACE FINISH:
 TOLERANCES:
 LINEAR:
 ANGULAR:

FINISH:
 リスト参照

DEBUR AND
 BREAK SHARP
 EDGES

DO NOT SCALE DRAWING

REVISION

NAME SIGNATURE DATE

DRAWN

CHK'D

APPV'D

MFG

Q.A.

MATERIAL:
 リスト参照

WEIGHT:

TITLE:
 ES9018-ASSY

DWG NO.
 ES9018

A3

SCALE:1:5

SHEET 1 OF 5

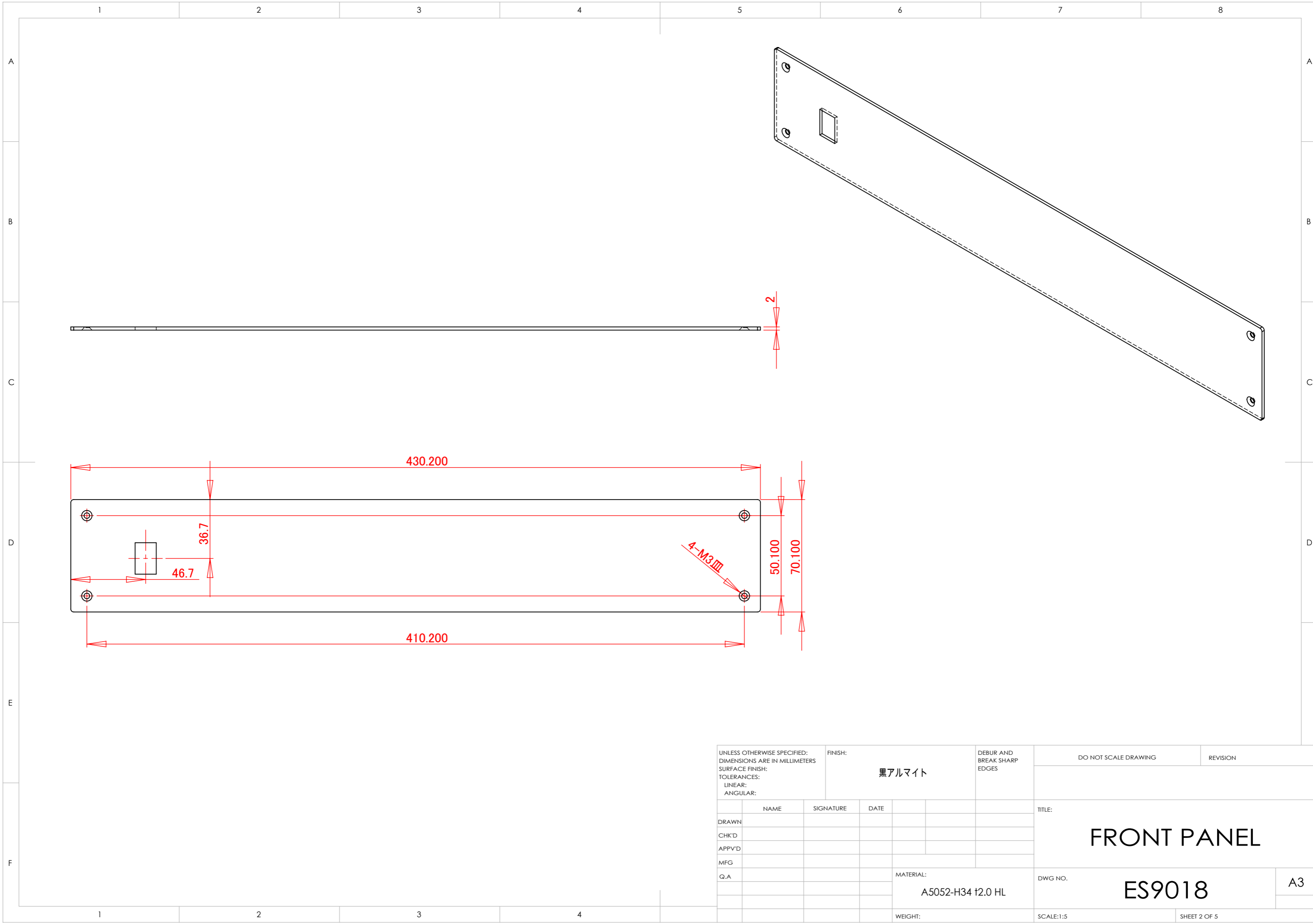

UNLESS OTHERWISE SPECIFIED: DIMENSIONS ARE IN MILLIMETERS SURFACE FINISH: TOLERANCES: LINEAR: ANGULAR:				FINISH: 黒アルマイト		DEBUR AND BREAK SHARP EDGES		DO NOT SCALE DRAWING		REVISION	
DRAWN				NAME		SIGNATURE		DATE		TITLE: FRONT PANEL	
CHK'D											
APPV'D											
MFG											
Q.A								MATERIAL: A5052-H34 t2.0 HL		DWG NO. ES9018	
								WEIGHT:		SCALE:1:5	
										SHEET 2 OF 5	
										A3	

1 2 3 4 5 6 7 8

A B C D E F

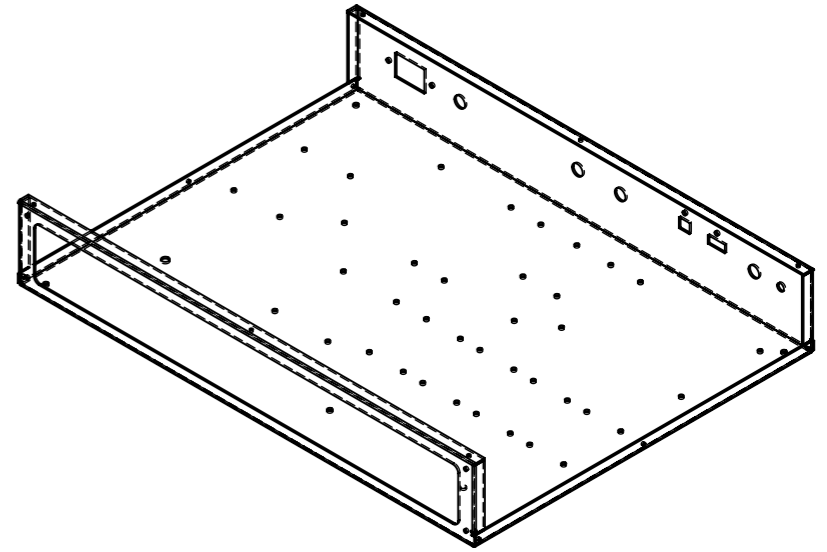
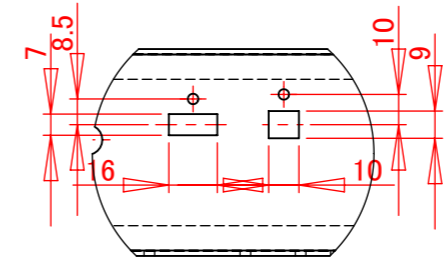
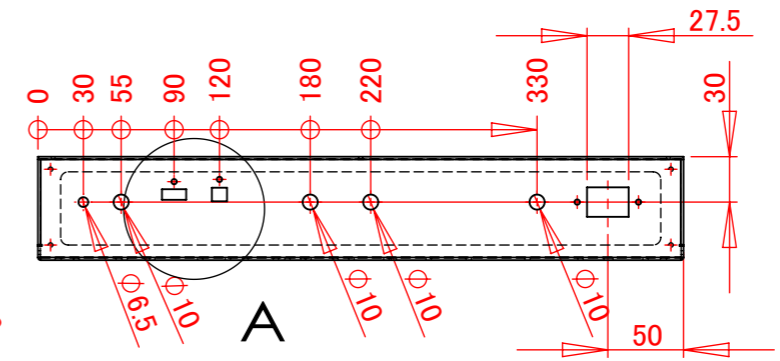
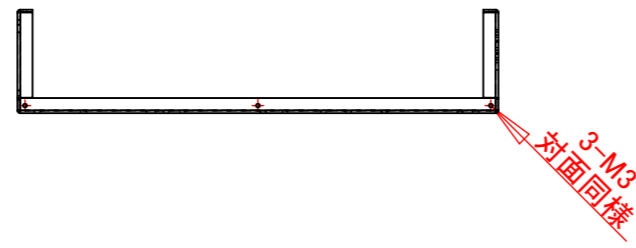
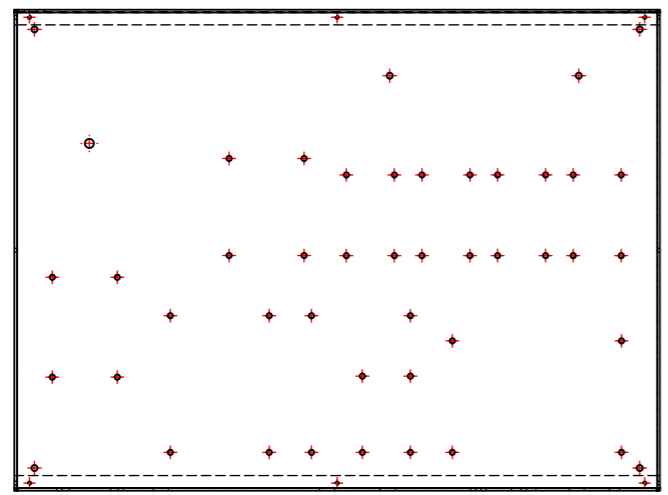
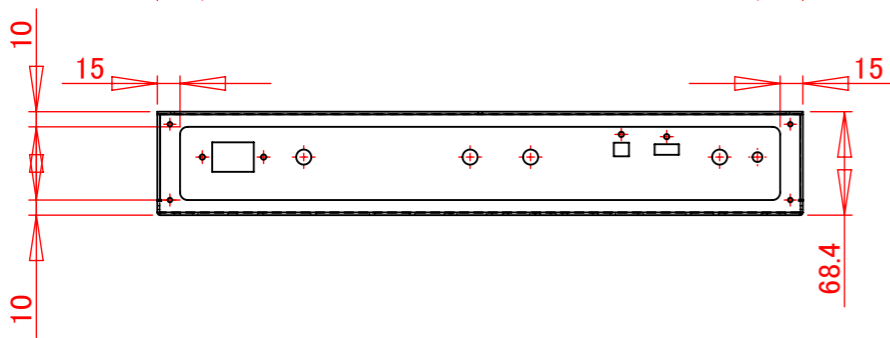
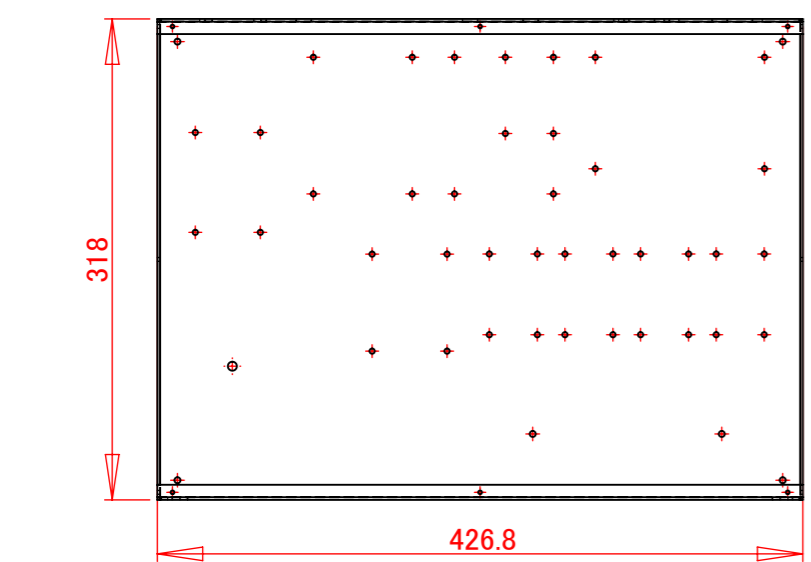

詳細図 A
スケール 2 : 5

UNLESS OTHERWISE SPECIFIED: DIMENSIONS ARE IN MILLIMETERS		FINISH: 黒半艶焼き付け塗装		DEBUR AND BREAK SHARP EDGES		DO NOT SCALE DRAWING		REVISION	
SURFACE FINISH:									
TOLERANCES:									
LINEAR:									
ANGULAR:									
DRAWN		NAME	SIGNATURE	DATE			TITLE:		
CHK'D							CHASSIS		
APPV'D									
MFG						MATERIAL:		DWG NO.	
Q.A						SPCC-SD t1.6		ES9018	
						WEIGHT:		SCALE:1:5	
								SHEET 3 OF 5	
								A3	

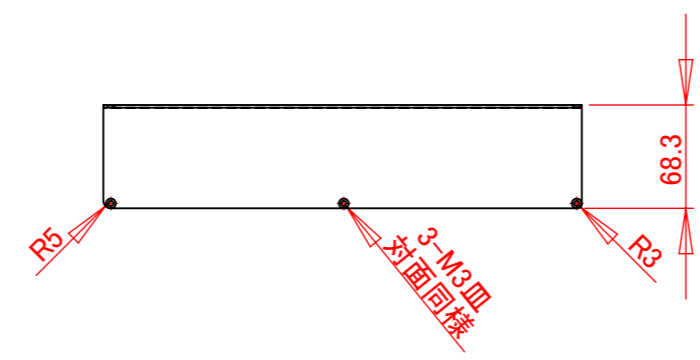
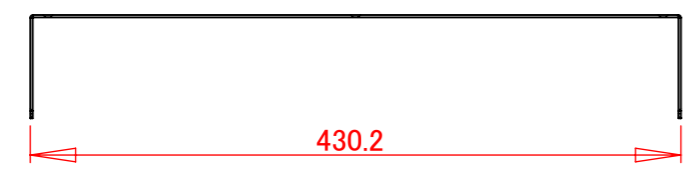
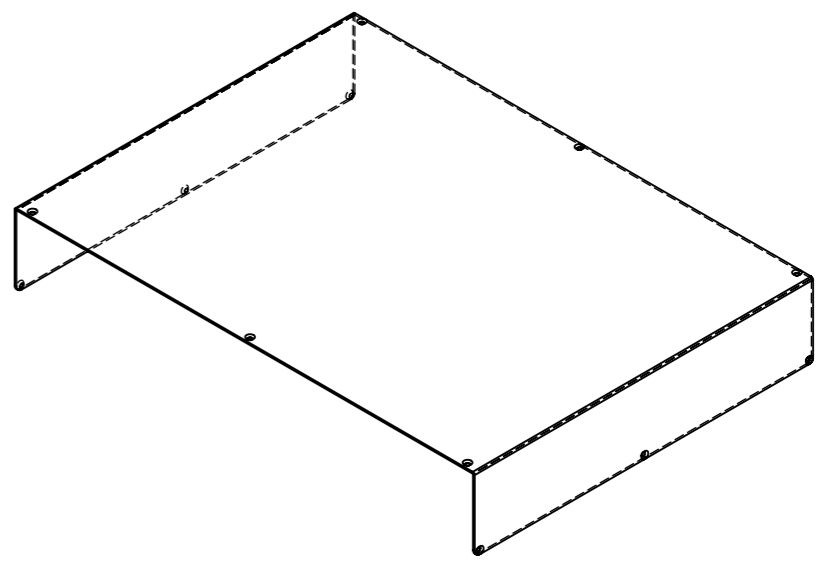
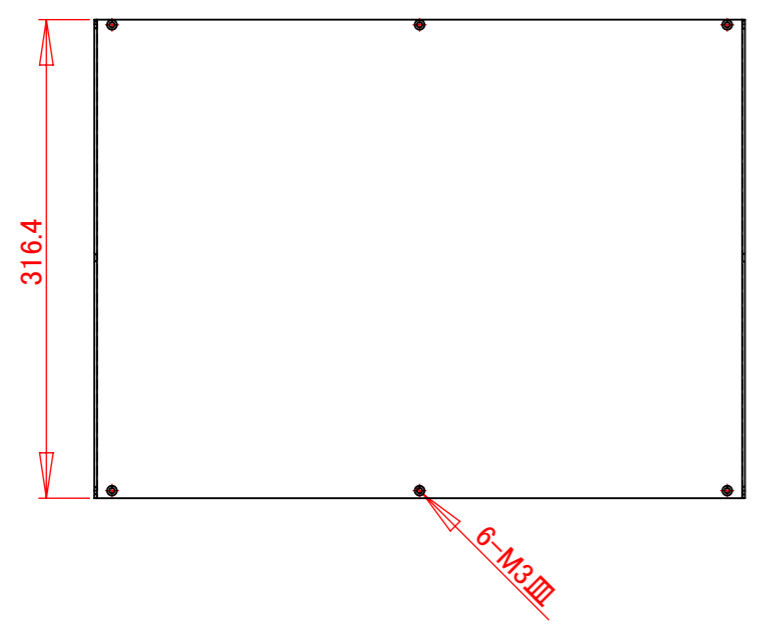

UNLESS OTHERWISE SPECIFIED: DIMENSIONS ARE IN MILLIMETERS				FINISH: 黒半艶焼き付け塗装		DEBUR AND BREAK SHARP EDGES		DO NOT SCALE DRAWING		REVISION	
SURFACE FINISH:								TITLE: COVER			
TOLERANCES:											
LINEAR:											
ANGULAR:											
DRAWN		SIGNATURE		DATE							
CHK'D											
APPV'D								DWG NO.		A3	
MFG						MATERIAL:		ES9018		SCALE:1:5	
Q.A						SPCC-SD t1.6					
						WEIGHT:		SHEET 4 OF 5			

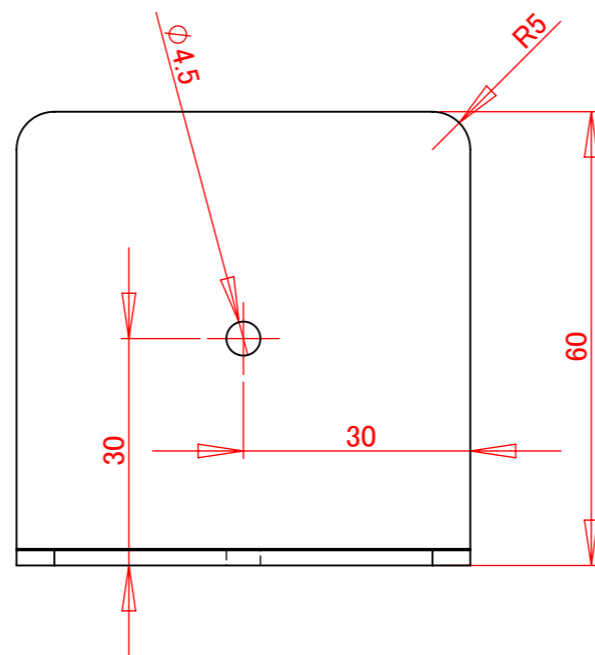
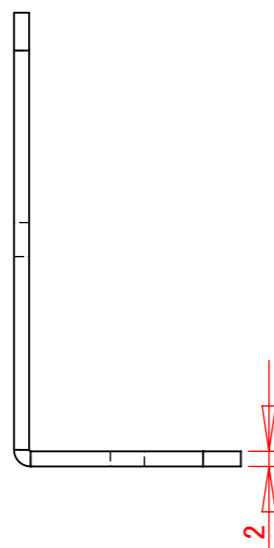
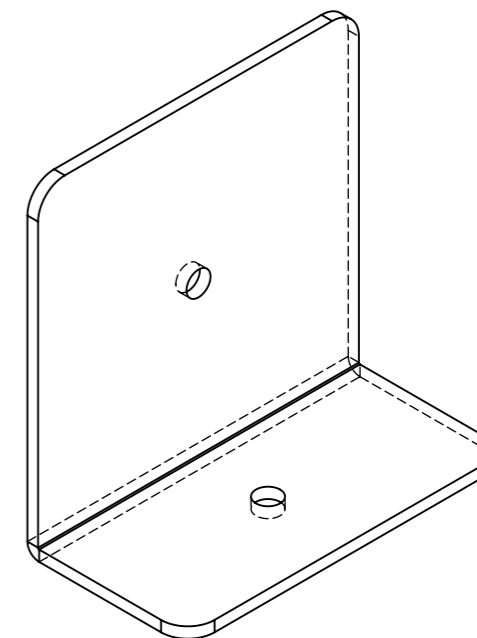
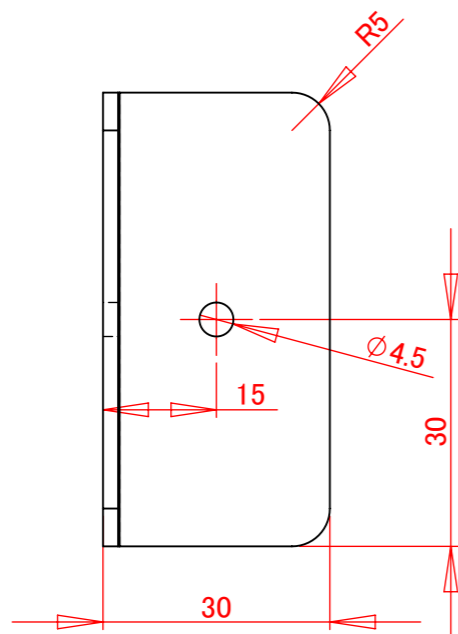

UNLESS OTHERWISE SPECIFIED: DIMENSIONS ARE IN MILLIMETERS			FINISH: ユニクロメッキ		DEBUR AND BREAK SHARP EDGES		DO NOT SCALE DRAWING		REVISION	
SURFACE FINISH:										
TOLERANCES:										
LINEAR:										
ANGULAR:										
DRAWN		NAME	SIGNATURE	DATE			TITLE: コイルブラケット			
CHK'D										
APPV'D										
MFG										
Q.A					MATERIAL: SPCC-SD t2.0		DWG NO. ES9018		A3	
					WEIGHT:		SCALE:1:5		SHEET 5 OF 5	